

A COMPLEX CURRENT RATIO DEVICE FOR THE CALIBRATION OF CURRENT TRANSFORMER TEST SETS

Hüseyin Çaycı

National Metrology Institute of Turkey (TUBITAK ÜME), Power & Energy Laboratory, P.O. Box:54, Gebze, 41470 Kocaeli, Turkey, (✉ huseyin.cayci@ume.tubitak.gov.tr, +90 262 679 5000)

Abstract

A practical method with high accuracy in generation and application of error values for calibration of current transformer test sets is described. A PC-controlled three-phase power source with a standard wattmeter is used for generating the nominal and error test currents while an electronically compensated current comparator is used to provide summation and subtraction of them, precisely. With this method, any ratio error and phase displacement values could be generated automatically and nominal and test currents could be grounded on the test set safely. Because of its high accurate ratio and phase error generating capability, any type of test set regardless of its operating principles could be calibrated.

Keywords: current transformer test set, ratio error, phase displacement, current comparator, compensation.

© 2011 Polish Academy of Sciences. All rights reserved

1. Introduction

Calibration of an instrument current transformer (CT) is commonly performed by comparison with a reference current transformer by using a current transformer test set (CTTS). Basically, the ratio error (ϵ) and phase displacement (δ) of a CT against a reference CT with the same ratio is determined by direct comparison of their secondary currents. Since the reference CT is assumed to be ideal and error-free, a CTTS directly gives ratio and phase differences of two secondary currents as in-phase and quadrature errors of the tested CT (Fig. 1a).

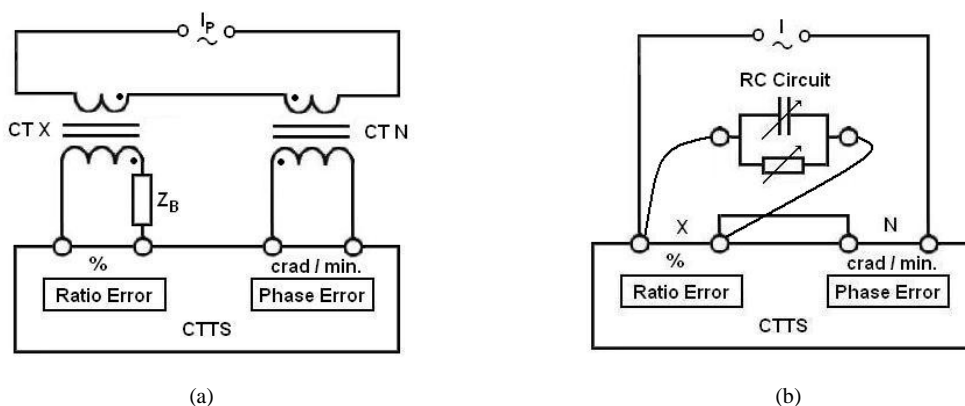

Fig. 1. (a) Basic CT calibration circuit with CTTS, (b) Calibration of a CTTS with R-C circuit application

Since the traceability of CT calibrations is directly dependent on the CTTS, several direct and indirect methods have been developed for their calibrations. Measuring individual components of a CTTS or inserting an R-C circuit between two input terminals of a CTTS (Figure 1b) are common methods for the calibration of electromechanical CTTSs. However, these methods are not applicable for some CTTSs, particularly for those having electronic circuits instead of passive components.

However, a calibration system [1] based on the generation of error values would be suitable for any type of CTTS. In this paper, a relatively practical and highly accurate calibration setup is discussed.

2. Theory of Operation

2.1. Generation of calibration values

Two isolated current signals with known ratio and phase differences are generated and evaluated by a three-phase current source, a wattmeter and an Electronically Compensated Current Comparator (ECCC). A current signal which is used for simulating the secondary current of a reference CT, is generated by first phase of the PC-controlled current source and applied both to N input of the CTTS and to the ECCC as main primary winding. An in-phase current signal which differs from reference signal by 0° or 180° is applied to one of the auxiliary windings of the ECCC. This current is adjusted via a home-made electronically compensated current divider. Finally, a quadrature-phase current signal which differs from the reference signal by $+90^\circ$ or -90° is generated by another phase of the source and applied to the second auxiliary winding of the ECCC. The secondary winding, which has the same number of turns as the primary winding, will then induce a complex total of the primary and two auxiliary currents proportional to their number of turns.

The ECCC has full isolation between the primary and secondary since it is necessary to ground the N and X current signals on the CTTS safely. Any error desired for a CTTS calibration can be obtained with the combination of a PC-controlled three-phase current source, an ECCC and an electronically-compensated current divider (ECCD).

2.2. Electronically-compensated current comparator

The compensated current comparator is a well-known highly accurate ratio standard [2]. Construction of a hollow toroid core prevents almost all external unwanted electromagnetic fields to reach the detector core so that the detector can sense the unbalanced currents almost without error. Because of this physical advantage, current comparator based ratio standards have been used in a wide range of applications.

Several techniques have been developed to achieve error-free current transformations. Recently, the introduction of electronic circuitry is preferred because of its simplicity and success in compensation. Use of electronic circuitry within the current comparator structure showed that one could design a current transformer with errors not more than a few ppm [3].

A special electronically-compensated current comparator (Fig. 2, Fig. 3) has been developed to use in a CTTS calibration system [4]. Similar to others, it has a detector core C_3 , a detection winding N_D , a hollow toroid core C_1 surrounding the detector core, a primary winding N_P and a secondary winding N_S .

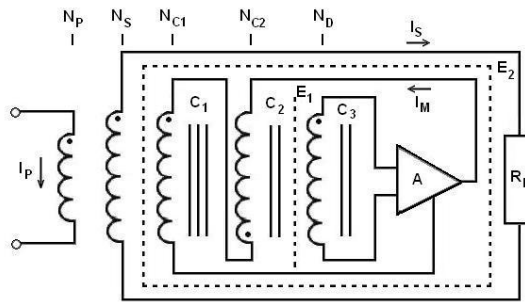

Fig. 2. Electronically-compensated current comparator

Then, two additional windings N_{C1} , N_{C2} with the same number of windings are wound inside and outside the hollow toroid core, and connected to each other in series but inversely. Their number of windings should not be the same as the secondary winding. Here, the dashed line E_1 represents a thin electrostatic shield (copper foil) surrounding the detector core and winding. C_2 represents a thick magnetic shield surrounding all. The dashed line E_2 shown in the figure represents a thick copper shield to prevent N_{C1} , the external compensation winding, from the stray fields of primary and secondary currents.

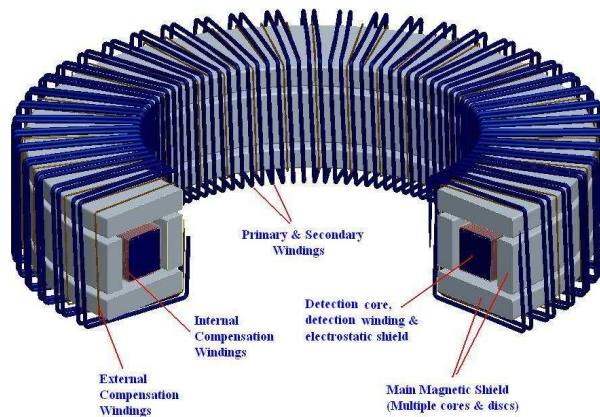

Fig. 3. Structure of the current comparator and its windings

The electronic circuitry is designed as a transconductance amplifier which amplifies the voltage obtained from the detector winding and converts it into a current. It forces this current to the inner and outer compensation windings not only for compensation of the secondary current but also for automatically zeroing the detection voltage,.

3. Performance tests and verification

The errors and linearity of the ECCC was measured in the unity ratio mode and with a maximum burden of 0.5Ω . First, a commercial CTTS, with the ratio error and phase displacement measurement resolution of 1ppm, was used. However, because of its instability below currents of 0.5A (10% of nominal current), an auxiliary CCC-based detector was used. The sensitivity of the auxiliary detector is ten times higher than that of the ECCC detector and

it gives more stable results than the commercial CTTS with lower excitation currents. The measurement results from both CTTS and auxiliary CCC, at currents between 1% and 200% of nominal current 5A, are given in Table 1.

Further tests on the ECCC showed that the errors given in the table are inherent errors of the ECCC. And, these inherent errors are almost phase errors which arise because of capacitive interactions between the primary, secondary and outer compensation windings.

Several additional tests have been performed not only to check the self-performance of the ECCC but also for verification of the calibration system including the three-phase current source and the ECCC.

The electronically-compensated current comparator has 200 turns (T) primary and secondary windings in a 1:1 ratio configuration. An additional 1T to the primary or secondary windings will mean $\pm 0.5\%$ ratio difference between primary and secondary currents. However, ratio errors obtained with an additional winding on the primary side can be compensated perfectly with the same configuration on the secondary or vice versa.

Table 1. Calibration results of ECCC in 1:1 ratio.

Applied Current	Measured Relative Error		
	Load 0.5 Ω		
	with CTTS		with CCC Detector
I_p	Ratio error	Phase displacement	Composite error
10 A	$\epsilon \leq -1$ ppm	$\delta \leq 2$ μ rad	1.3 ppm
5 A			1.4 ppm
2 A			1.7 ppm
1 A			1.6 ppm
0.5 A			1.6 ppm
0.2 A			1.6 ppm
0.1 A			1.2 ppm
0.05 A			0.5 ppm

Additional or inverse windings up to 10T on the primary and secondary showed no significant additional error from 1% up to 200% of nominal current.

Then, such ratio errors obtained with the primary or secondary winding configurations were tried to be compensated with auxiliary windings and appropriate currents applied from the second phase of the current source. Since the basic amplitude accuracy of the source together with the reference wattmeter is below 100 ppm, a 1T compensation results in a negligible error (less than 1 ppm). Appropriate tests with different winding configurations result with errors not greater than 5 ppm.

Similar tests were performed by using two auxiliary windings and ignoring any additional primary or secondary windings. Any ratio error generated by a current from the second phase of the current source and by using one of the auxiliary windings was compensated successfully, with currents applied from the third phase to the other auxiliary winding.

Finally, similar tests were performed for the verification of the system in generating the phase displacements. Since the phase accuracy of each phase is not worse than 100 μ rad (0.005 $^\circ$), the final errors will also be very low. Both ratio- and phase-related test results showed a good agreement with the theoretical considerations.

3.1. Uncertainty budget of the calibration system

The model function of the calibration system is divided into two as for ratio error and phase displacement, respectively.

Ratio error, ϵ_X : In the current transformer calibration, secondary currents of the reference current transformer and the current transformer to be calibrated are compared on a current transformer bridge. The calibration of the current transformer bridge is performed by applying two secondary currents with known ratio error and phase displacement related to each other. Consequently, the ratio error of the current transformer bridge is defined by the following formula (in ppm):

$$\epsilon_X = \frac{I_{SX} - I_{SN}}{I_{SN}} \cdot 10^6, \quad (1)$$

where, I_{SX} is the amplitude value of the current signal to be calibrated and I_{SN} is the amplitude value of the reference current signal.

The model function of the system is then,

$$\epsilon_X = \epsilon_{xi} - \delta\epsilon_{XRcal} - \delta\epsilon_{XRd} - \delta\epsilon_{XConfig}, \quad (2)$$

where $\delta\epsilon_{XRcal}$ is the parameter for ratio uncertainties of current comparator and wattmeter, $\delta\epsilon_{XRd}$ is the drift effect of those references, and $\delta\epsilon_{XConfig}$ is the effect of measurement setup including temperature, electromagnetic field effects etc.

Phase displacement, δ_X : Phase displacement in the current transformer bridge is the phase difference between the vectors of two current signals. It is denoted in radians or minutes.

The model function of the system is then,

$$\delta_X = \delta_{xi} - \delta\delta_{XRcal} - \delta\delta_{XRd} - \delta\delta_{XConfig}, \quad (3)$$

where $\delta\delta_{XRcal}$ is the parameter for phase displacement uncertainties of current comparator and wattmeter, $\delta\delta_{XRd}$ is the drift effect of those references, and $\delta\delta_{XConfig}$ is the effect of measurement setup including temperature, electromagnetic field effects etc.

All uncertainty contributions for the developed current transformer test set calibration system are given in the following table.

Table 2. Uncertainty budget of the calibration system for current transformer test sets.

Source of Uncertainty	Standard Uncertainty		Probability Distribution	Contribution to the Standard Uncertainty	
	($\mu\text{A/A}$)	(μrad)		($\mu\text{A/A}$)	(μrad)
Generating error values (wattmeter & divider)	2	5	Normal	2	5
Current Comparator (1:1 ratio & summing)	1	1	Normal	1	1
Measurement setup	<1	<1	Rectangular	<1	<1
Standard Uncertainty of Measurement	<1	<1	Normal	<1	<1
Standard Uncertainty (k=1)				2,3	5,1
Standard Uncertainty (k=2)				5	10

Here, the improvement in the calibration system by using a divider could easily be seen. The uncertainty in the generation of phase error is directly related with the phase uncertainty of the wattmeter which could be $5\mu\text{rad}$ in the worst case. However, the uncertainty in

generation of the ratio error is independent of the wattmeter uncertainty, and it could be reduced down to 2ppm which is the uncertainty of the electronically compensated current divider.

3. Conclusions

An automatic calibration system for current transformer test sets has been described. With this method, any ratio error and phase displacement value could be generated automatically and nominal and test currents could be safely grounded in the test set. Because of its highly accurate ratio and phase error generating capability, any type of test set regardless of its operating principle could be calibrated. It is obviously seen that the errors in generating the desired values will never affect the overall uncertainty of the calibration system more than 5 ppm and 5 μ rad for ratio and phase error measurements, respectively. The overall uncertainty of the system is not more than 5 ppm for ratio and 10 μ rad for phase, independent of the measured ratio and phase error values including dividers.

In the future, it is planned to design a similar electronically compensated current comparator to use it in a new calibration system for the 1A current range. Additionally, to eliminate the instabilities of the designed ECCC below a certain percentage (<10%) of the nominal current, two auxiliary ECCCs will be designed, one for the 5A range and the other for 1A. The nominal currents of those ECCCs will be 0.5A and 0.1A, respectively.

Acknowledgements

The assistance of the Power & Energy Laboratory staff in the construction of the CCC, in the design and the adoption of the electronic circuit and in the testing of the ECCC is greatly appreciated.

This work is part of a research project entitled "Investigation of Magnetic and Capacitive Error Components of Current Transformers Together With Burden Effects and Development of Compensation Methods" supported by the scientific and technological research projects support program (1001), sponsored by The Scientific and Technological Research Council of Turkey (TÜBİTAK) (grant # 109E097), and by National Metrology Institute of Turkey (UME) (grant # G1LV-E9-04-A).

References

- [1] Ramm, G., Roeissle, G., Latzel, H.G. (1998). Rechnergesteuerte Kalibrierung von Messeinrichtungen für Strom- und Spannungswandler. *PTB-Mitteilungen*, 108, 188-200.
- [2] Moore, W.J.M., Miljanic, P.N. (1988). The current comparator. *Inst. Elec. Eng. Electrical Measurement Series*. London. UK. Peter Peregrinus, 4.
- [3] Miljanic, P.N, So, E., Moore, W.J.M. (1991). An electronically enhanced magnetic core for current transformers. *IEEE Trans. Instrum. Meas.*, 40(2).
- [4] Çaycı, H. (2010). Electronically compensated current comparator. *TUBITAK UME Technical Report*.